

Wymiary

Urządzenia wewnętrzne

Urządzenia ściennie MSZ Diamond, chłodzenie / grzanie, MSZ-LN18-60VG2 R/W/B

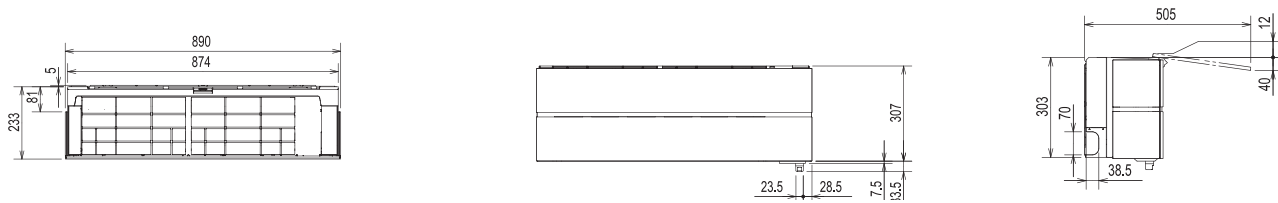

Inwerterowe urządzenia ściennie Premium MSZ, chłodzenie / grzanie, MSZ-EF18-50VGK W/B/S

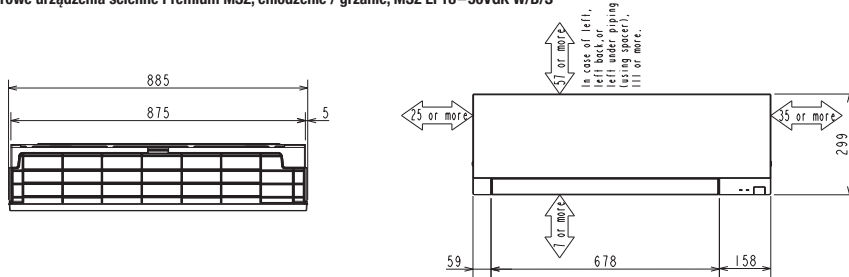

Inwerterowe urządzenia ściennie MSZ, chłodzenie / grzanie, MSZ-AP15/20VG

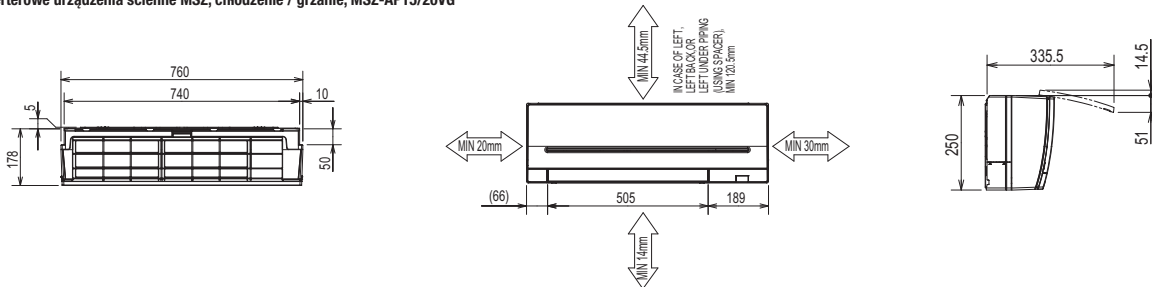

Inwerterowe urządzenia ściennie MSZ, chłodzenie / grzanie, MSZ-AP25-50VGK

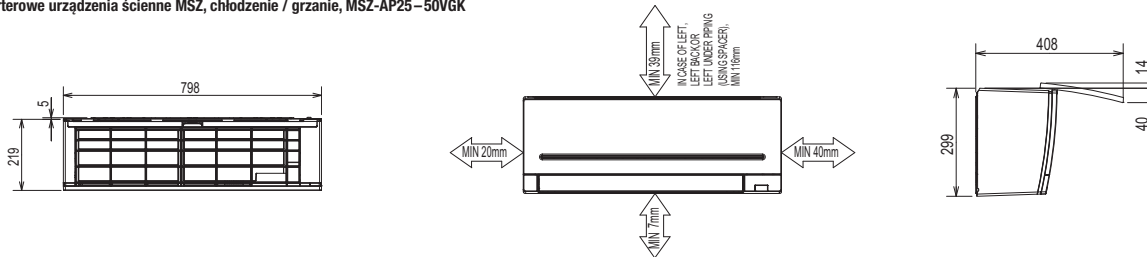

Inwerterowe urządzenia ściennie MSZ, chłodzenie / grzanie, MSZ-AP60/71VGK



Urządzenia wewnętrzne

Inwerterowe Urządzenia przypodłogowe MFZ, chłodzenie / grzanie, MFZ-KJ25 – 50VE; MFZ-KT25 – 60VG

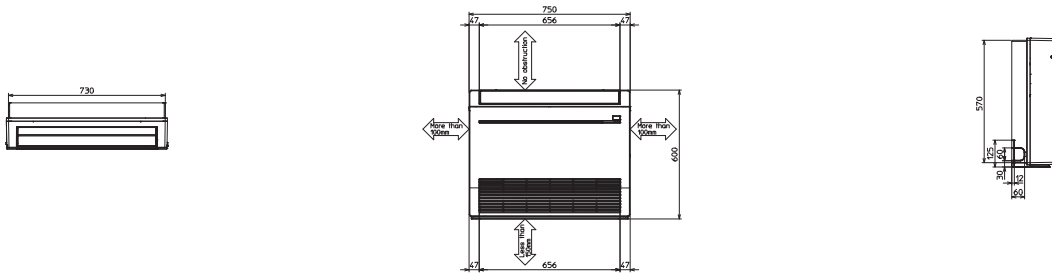

Urządzenia kasetonowe 1-stronne MLZ, chłodzenie / grzanie, MLZ-KP25 – 50VF

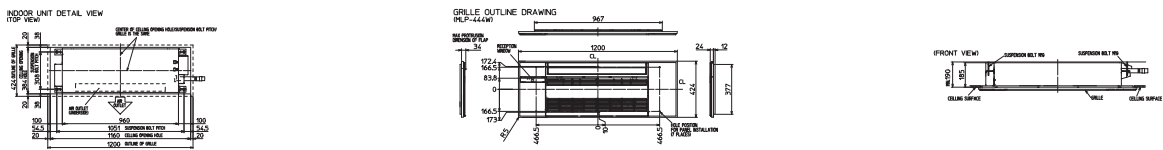

Urządzenia kasetonowe 4-stronne SLZ, chłodzenie / grzanie, SLZ-M15 – 60FA

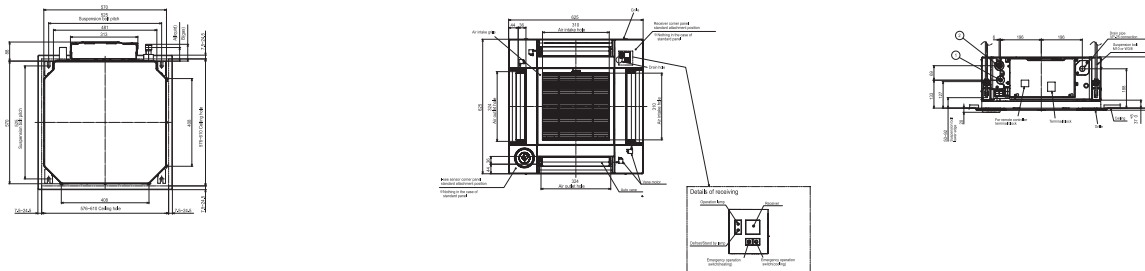

Urządzenia kanałowe SEZ, chłodzenie / grzanie, SEZ-M25 – 71DA

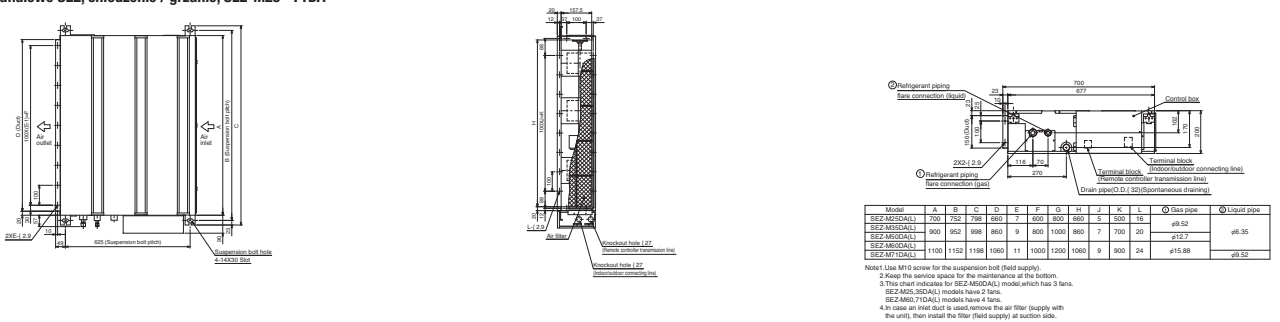

Urządzenia zewnętrzne

Inwerterowe urządzenia zewnętrzne MUZ, chłodzenie / grzanie, MUZ-LN25 / 35VG2 / VGHZ

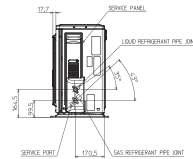
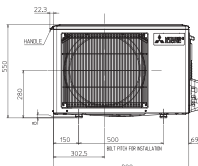
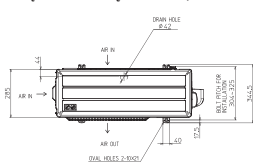

Inwerterowe urządzenia zewnętrzne MUZ, chłodzenie / grzanie, MUZ-LN50VG2

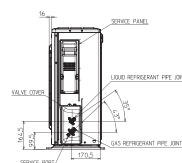
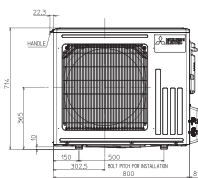
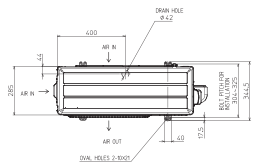

Inwerterowe urządzenia zewnętrzne MUZ, chłodzenie / grzanie, MUZ-LN50VGHZ / 60VG

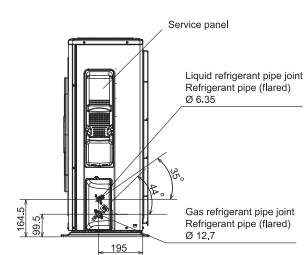
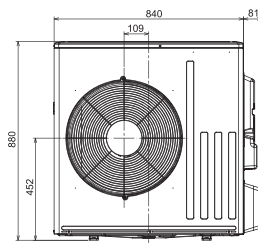
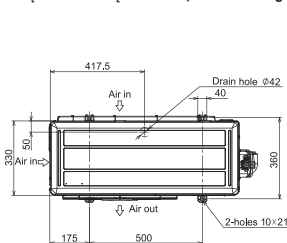

Inwerterowe urządzenia zewnętrzne MUZ, chłodzenie / grzanie, MUZ-EF25 – 42VG

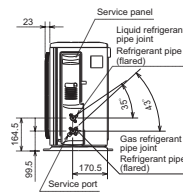
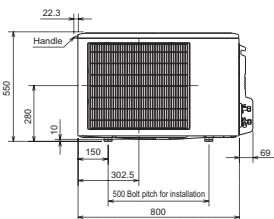
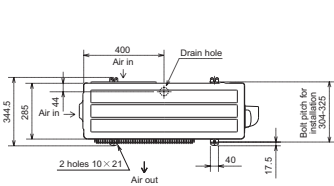

Inwerterowe urządzenia zewnętrzne MUZ, chłodzenie / grzanie, MUZ-EF50VG

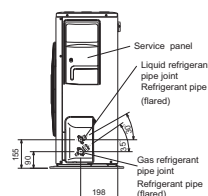
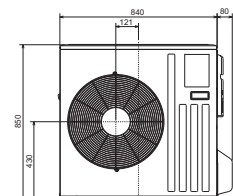
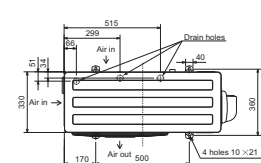

Urządzenia zewnętrzne

Inwerterowe urządzenia zewnętrzne MUZ, chłodzenie / grzanie, MUZ-AP20-42VG

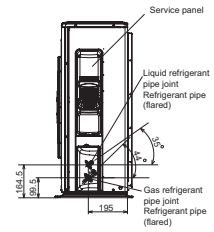
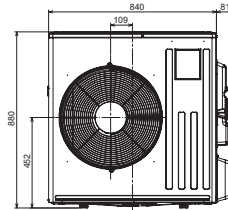
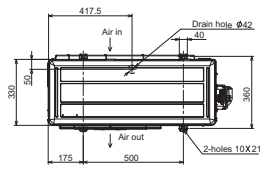

Inwerterowe urządzenia zewnętrzne MUZ, chłodzenie / grzanie, MUZ-AP50VG

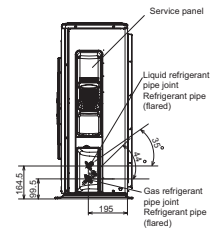
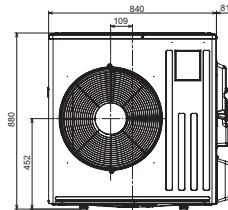
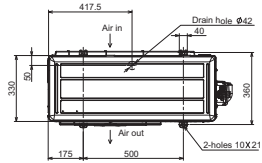

Inwerterowe urządzenia zewnętrzne MUZ, chłodzenie / grzanie, MUZ-AP60/71VG

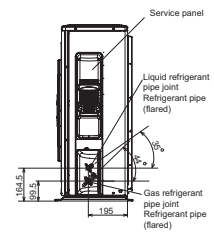
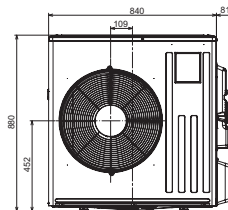
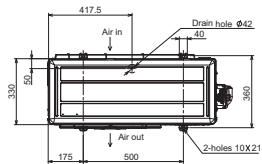

Urządzenia zewnętrzne

Inwerterowe urządzenia zewnętrzne MUFZ, chłodzenie / grzanie, MUFZ-KJ25 / 35VEHZ

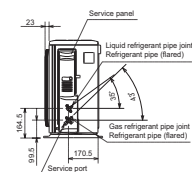
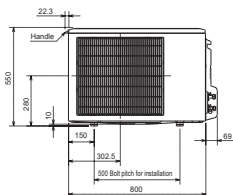
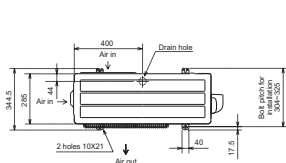

Inwerterowe urządzenia zewnętrzne MUFZ, chłodzenie / grzanie, MUFZ-KJ50VEHZ

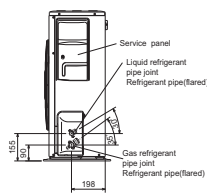
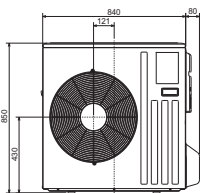
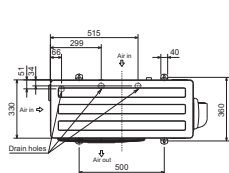

Inwerterowe urządzenia zewnętrzne SUZ, chłodzenie / grzanie, SUZ-M25/35VA

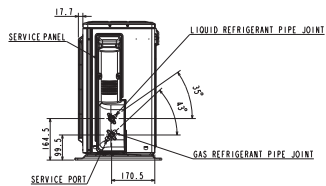
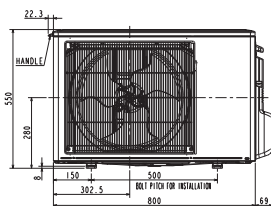
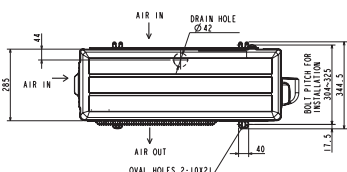

Inwerterowe urządzenia zewnętrzne SUZ, chłodzenie / grzanie, SUZ-M50VA

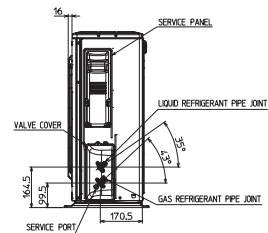
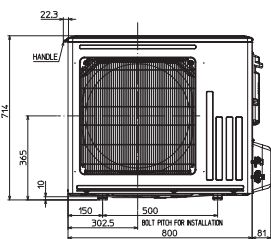
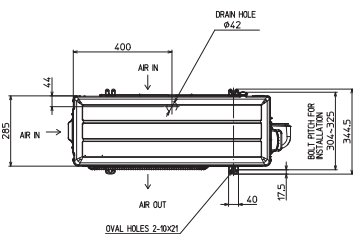

Inwerterowe urządzenia zewnętrzne SUZ, chłodzenie / grzanie, SUZ-M60/71VA

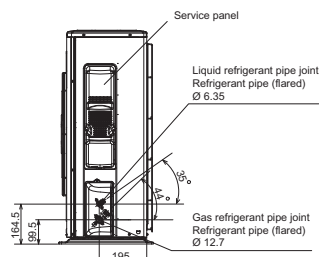
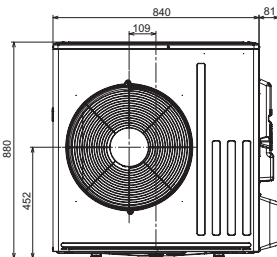
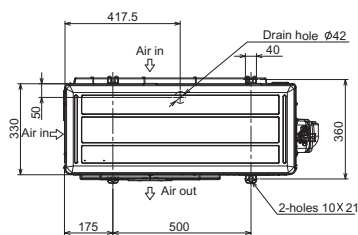

Urządzenia zewnętrzne

MXZ-2F33-53VF3

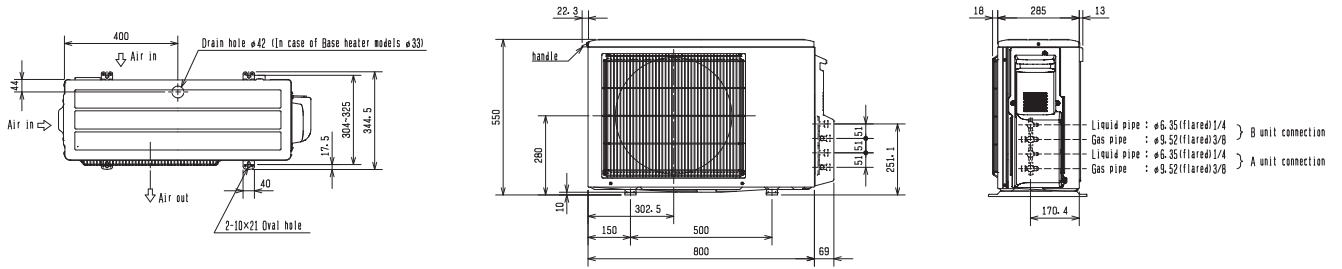

MXZ-3F54/68VF3

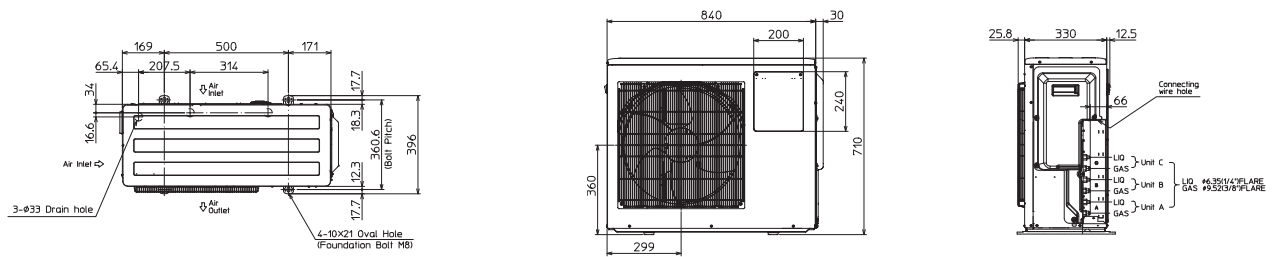

MXZ-4F72/80VF3

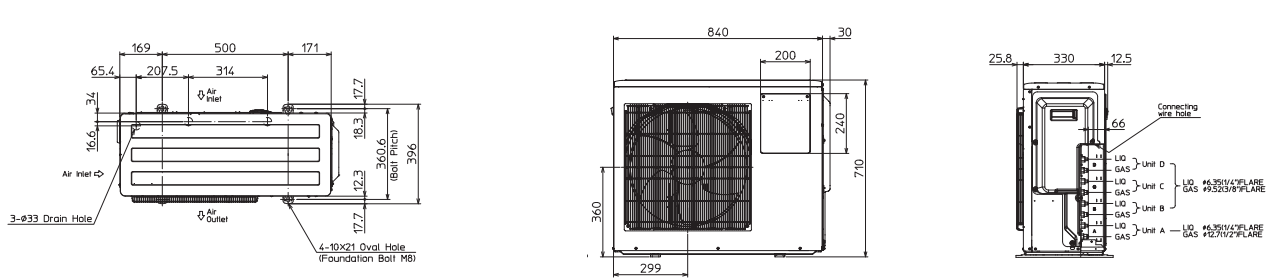

MXZ-4F83VF

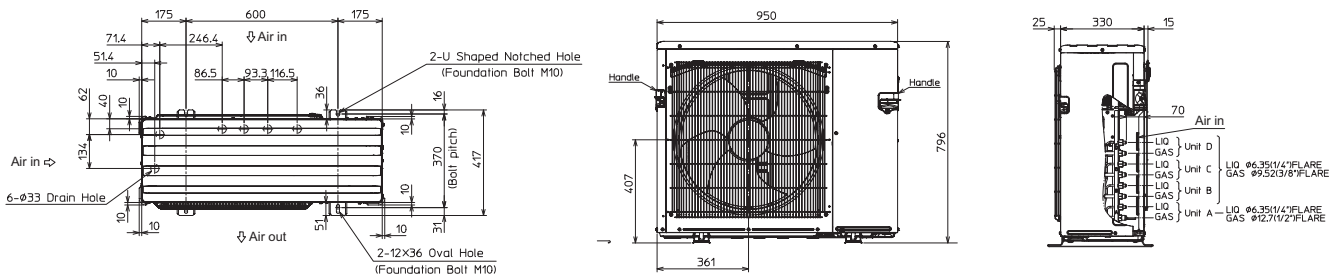

Urządzenia zewnętrzne

MXZ-5F102VF

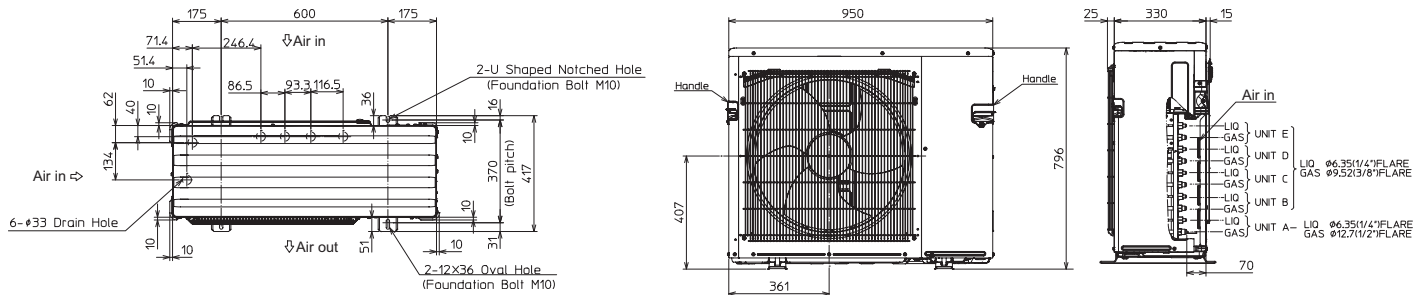

MXZ-6F122VF

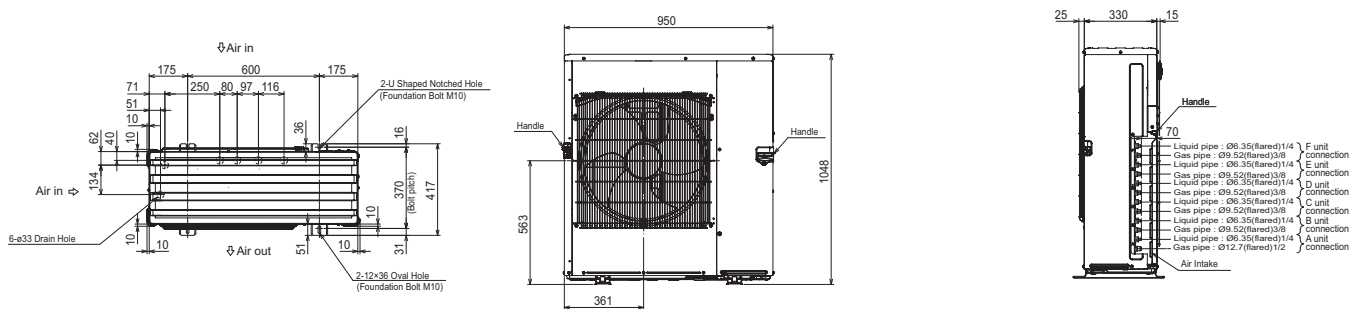

MXZ-2F53VFHZ

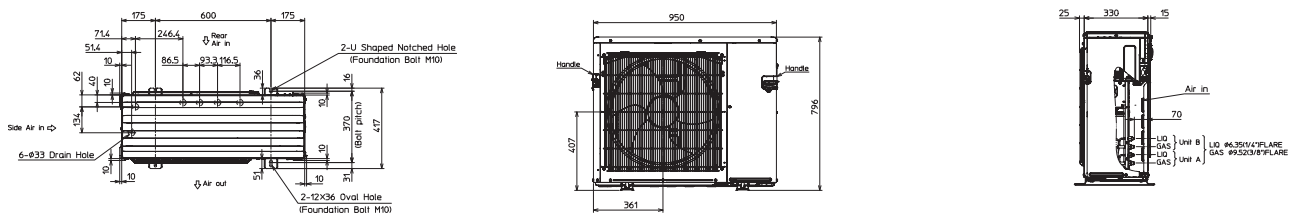

MXZ-4F83VFHZ

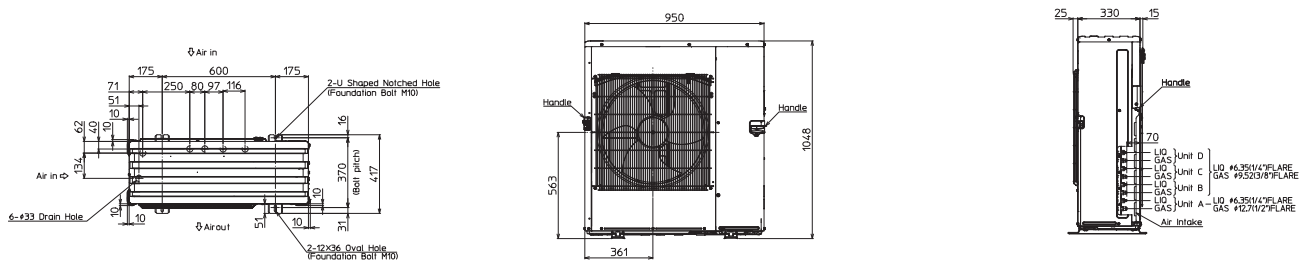

Rozdzielacze do jednostek zewnętrznych PUMY-P YKM/VKM

PAC-MK33BC

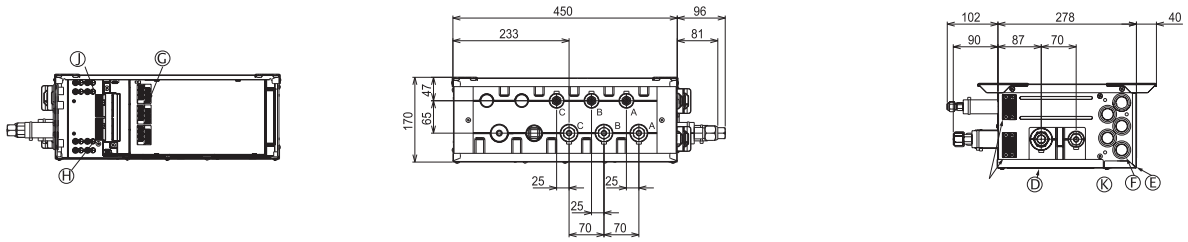

PAC-MK53BC

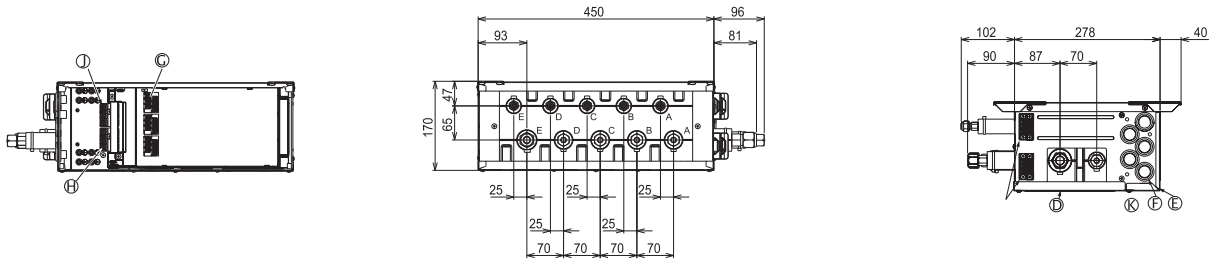

PAC-LV11M-J

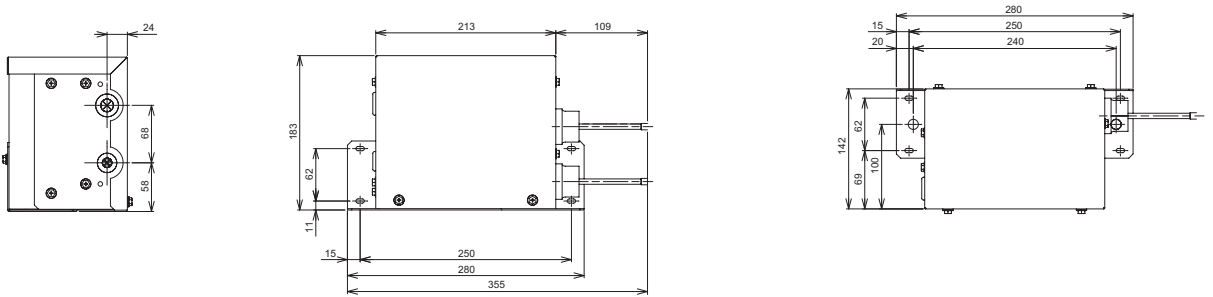

Urządzenia zewnętrzne

PUMY-P112-140VKM/YKM

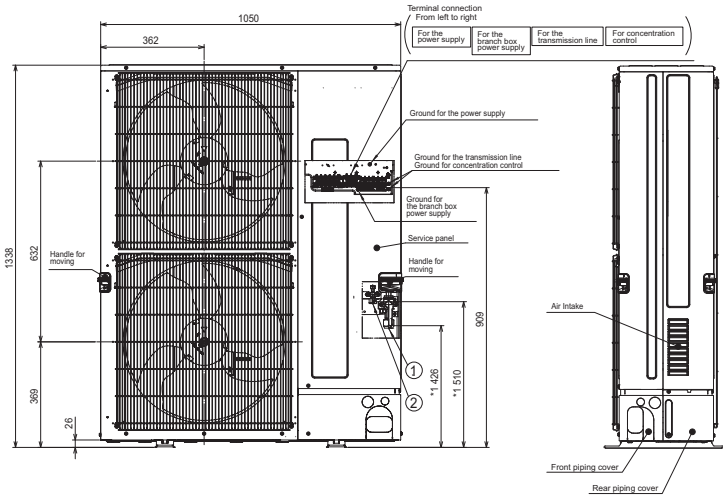
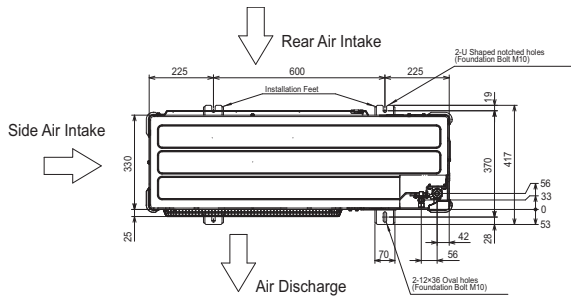

PUMY-SP112-140VKM/YKM

